

Battery Protection Circuits

Rev 1.0 – Bruce White – June 7th 2009

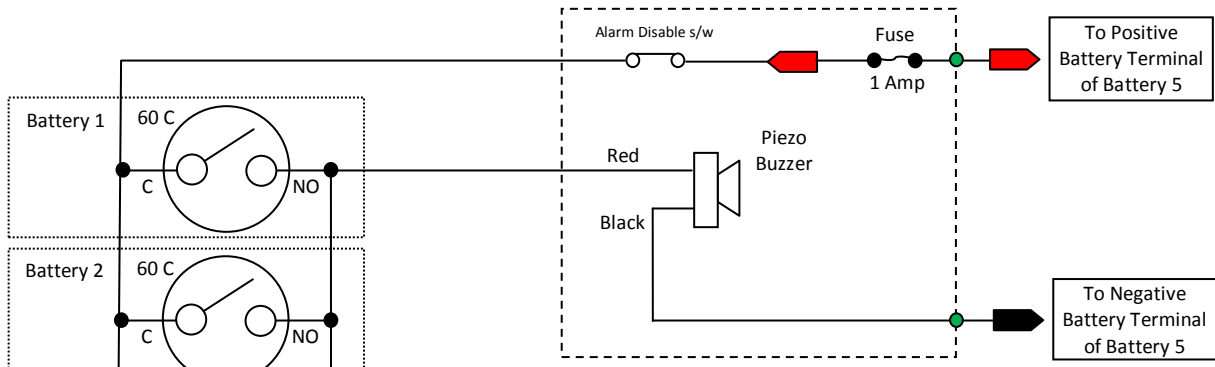
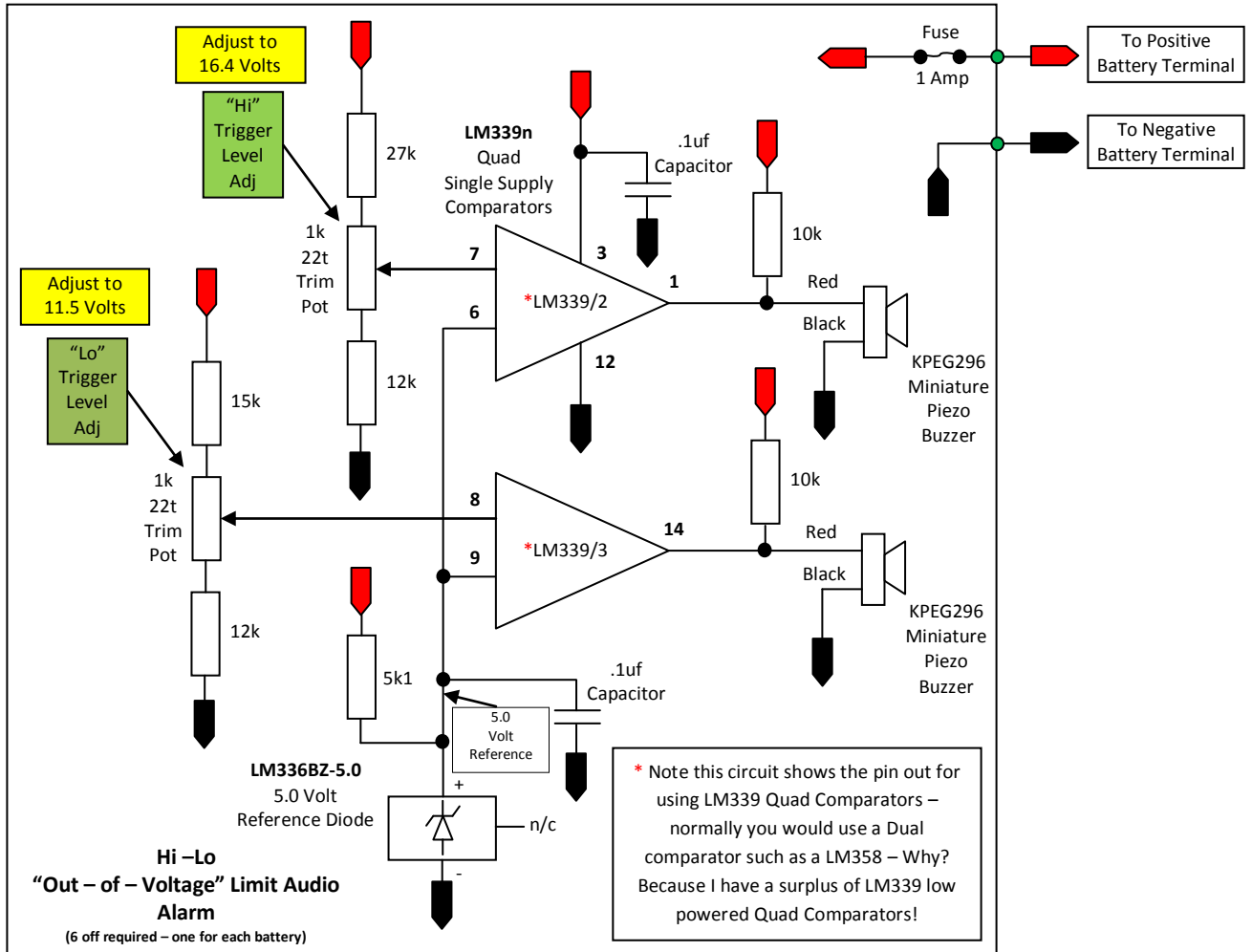

Battery Over Temperature Alarm

(Preset 60 degree C)

6 Off –Thermo
Protection Sensors Switches
Preset contact closure @60 C
RS 229-5979
(Normally Open)